

Introducing the TD6M Series Melt Pressure Mechanical Gauge.

SERIES: TD6M



FEATURES

- Diaphragm isolation configuration
- Direct pressure display without power
- Easy to install, high reliability

DESCRIPTION

The TD6M Series melt pressure gauges adopt high performance component and special construction design, on the rigid stem version the mechanical gauge can be rotated 270° for unobstructed viewing, easy to install, zero adjustable, and they are the ideal choices for applications requiring simple maintenance free pressure indication.

DIMENSIONS

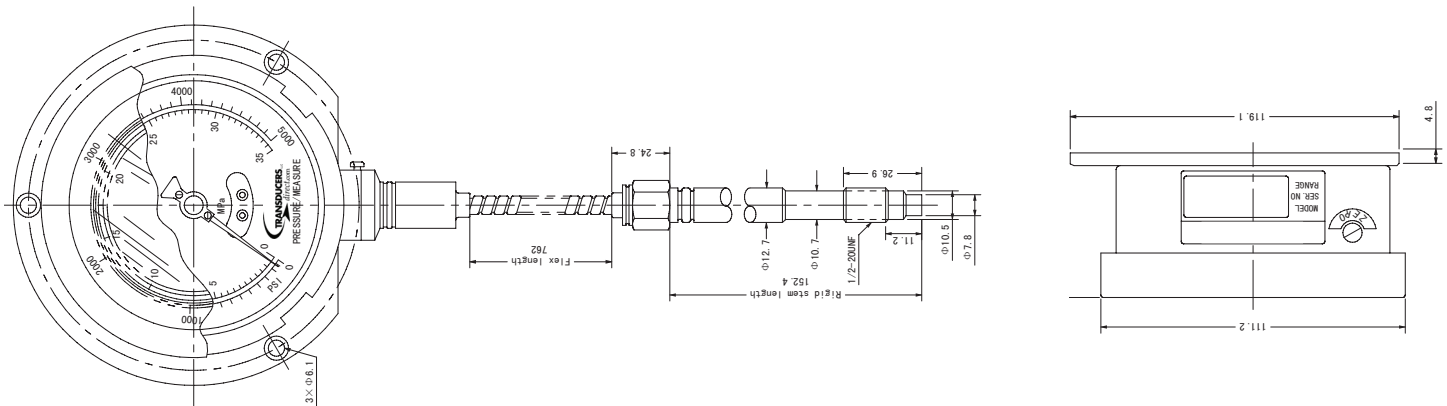

Dimensions In mm And Are Reference Only.

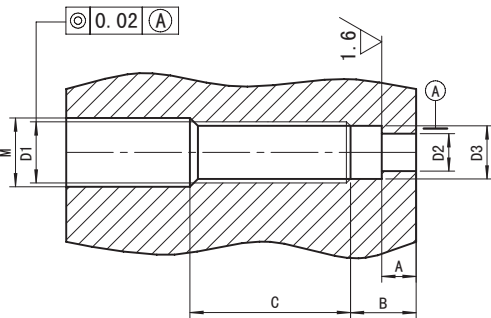
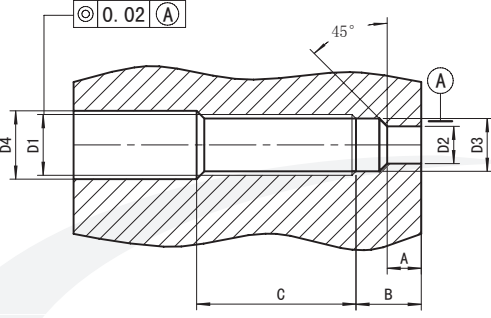
 <p>Planar sealed</p>	D1	M2 2×1.5	M28×1.5	G3/4"	PT3/8 "
	D2	Φ 16.1	Φ 18.3	Φ 18.3	Φ 10.3
	D3	Φ 20.1	Φ 26.1	Φ 24.2	Φ 14.9
	M	Φ 23	Φ 30	Φ 21	Φ 11
	A	11	12	12	14
	B	12	15	15	19
	C	40	35	35	40
 <p>45° Slope sealed</p>	D1	M1 2×1.5	M14×1.5	1/2-20UNF	M18×1.5
	D2	Φ 8	Φ 8	Φ 8	Φ 10.1
	D3	Φ 10.8	Φ 12.5	Φ 11.5	Φ 16.1
	D4	Φ 12.5	Φ 14.5	Φ 13.1	Φ 20
	A	6	6	6	6.5
	B	9	9.5	9.5	10

SPECIFICATIONS

Ranges	5000psi or 10,000psi
Combined error	±3%FS
Zero adjustability	±6%FS
Over pressure	1.5×FS
Max diaphragm temperature	750°F (400°C)
Case Material	Stainless Steel with Safety Glass
Process connection	1/2 -20UNF, M18×1.5
Standard Fill	*Mercury

*This product contains mercury and must be disposed of properly as hazardous waste.

ORDERING

Series	Output	Pressure	Accuracy	Stem	Flex	Thread	Connector	Diaphragm
TD6M	0	10M	3	6	30	U	00	R
TD6M	none	5 M = psi x 1000 10 M = psi x 1000	3= 3.00%	6 = 6" 12 = 12" **	0 = no flex 30 = 30" **	U = 1/2"-20 M = M18 x 1.5	none	R = 17-4 stainless

**= Consult factory for further options.
This product contains mercury.

Specifications may change without notice. The information we supply is believed to be accurate and reliable as of this printing. However, we assume no responsibility for its use. While we provide application assistance personally, through our literature and the Transducers Direct website, it is up to the customer to determine the suitability of the product in the application.

REV: 11.21